

MAXXUM

110 | 125 | 140 HP TRACTORS



CASE IH



Every year, a growing world demands more food, more fibre, more fuel and you have to produce it with less land, less resources and a greater focus on sustainability. Case IH is there to help you be ready with people who work alongside you that understand your operation and your needs. We're there with equipment designed to help you get more done and do it more efficiently, livestock, farmers and mixed-farm enterprises can count on Maxxum tractors to be ready for anything the season ahead throws at you. The Case IH Maxxum name dates back to the launch of the legendary 5100 series in 1990, followed by the MX series of which many are still in front line use around the country. Today's Maxxum range has inherited the functional dependability of its predecessors with easy operation to suit operators with various levels of experience.

CASE IH MAXXUM — PROVEN IN NEW ZEALAND

For when you have serious business to do

CAB SUSPENSION

Reducing the shock loads to the operator by 25 percent, the Maxxum cab suspension is standard fit on the Ultimate spec and offers superior operator comfort, both on the road and in the field. Designed with durable components, this adjustable mechanical system offers five settings and 100mm of cab travel.

POWERHOUSE

Maxxum tractors are powered by proven Case IH FPT Tier 3 engines with mechanical injection, minimal electronics and no DPF filters or DEF for easy and worry free maintenance. These engines provide reliable horsepower with plenty of low down torque. Work longer with less interruptions with 600 hour engine service intervals.

BETTER VISIBILITY

The Maxxum cab offers unobstructed vision in all directions, including a high visibility roof with an opening sunroof. The narrow, sloping bonnet is closely formed around the engine for great forward visibility – up to 3 metres more than some of the competition.



THE RIGHT GEAR FOR THE JOB

Semi Power Shift

All Case IH Maxxum tractors come standard with the durable 16x16 semi-powershift transmission. The Ultimate spec model comes with an Auto Field and Road mode. This will automatically change through up to eight gears depending on engine speed and load.

The cab model options are available with a 17x16 50km/h option from factory, this option includes front suspension with a braked front axle. They also have Reverse memory as standard; this function remembers which reverse gear was last selected when the tractor is shuttled- especially useful during repetitive loader work. For specialty operations such as vegetable growing or mulching, a creeper gearbox can be fitted in factory or at dealership.

READY FOR ANY IMPLEMENT

Hydraulics, linkage & PTO

Maxxum tractors are equipped with Cat 2/3 rear linkage with a generous lift capacity – more than most in its class. The standard hook ends make switching implements child's play.

The rear PTO is engaged electro-hydraulically, and has up to three PTO speeds.

CCLS 113 l/min hydraulic pump with 47 l/min dedicated steering and transmission pump gives the benefit of maintaining full hydraulic flow to a loader or implements even while steering. The remote valves are configurable with flow control. There is the ability to fit Load Sensing couplers to the tractor to run the latest implements including fertiliser spreaders to utilise the full flow of the pump- but only when it is needed, also saving fuel.

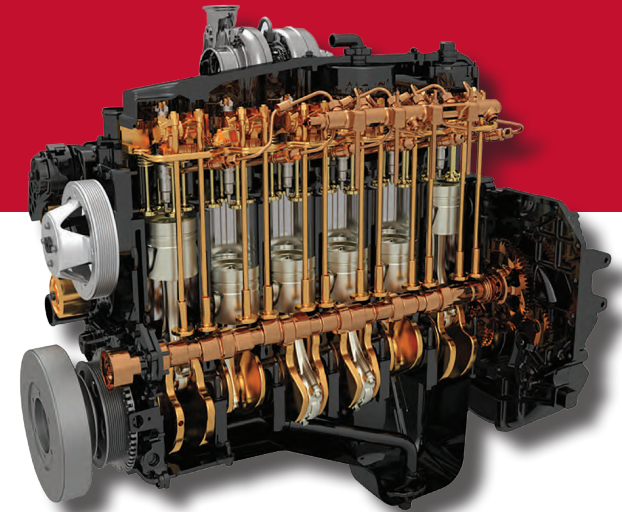

MAXXUM SERIES TRACTOR SPECIFICATIONS	MAXXUM 110 ROPS	MAXXUM 125 ROPS	MAXXUM 110 CAB	MAXXUM 125 CAB	MAXXUM 140 CAB
ENGINE					
Manufacturer, type, emission level	Case IH FPT NEF, Turbo Inter-cooled Diesel, Tier 3				
Cylinders / Capacity (cc)	4 / 4,485	6 / 6,728	4 / 4,485	6 / 6,728	6 / 6,728
Rated Power @ 2,200 rpm (hp/kW) ECE R120 ¹	112 / 82	126 / 93	112 / 82	126 / 93	141 / 104
Max torque (Nm @ rpm) ECE R120 ¹	510 @ 1,400	555 @ 1,250	510 @ 1,400	555 @ 1,250	625 @ 1,250
Torque Rise (%)	43	38	43	38	39
Fuel Tank Capacity	176	250	176	250	250
TRANSMISSION					
Type	Wet clutch, semi-powershift, powershuttle				
24 x 24, 40 km/h (2 speed SPS)	○	-	-	-	-
16 x 16, 40 km/h (4+4 speed SPS)	●	●	●	●	●
17 x 16, 50 km/h (4+4 speed SPS)	-	-	○	○	○
AXLES					
Steering Angle / Optimum turning Radius (m)	55° / 4.04	55° / 4.36	55° / 4.04	55° / 4.36	55° / 4.36
Front LSD / Front Diff lock / Front Suspension	● / - / -	● / ○ / -	● / ○ / ○	● / ○ / ○	● / ○ / ○
Four wheel drive engagement	Electro - Hydraulic with Auto 4WD option				
POWER TAKE OFF					
Type	Electro- Hydraulic, in cab shiftable with progressive engagement				
PTO Speeds	540/540E/1000		Classic: 540/1,000, Ultimate: 540/540E/1,000		
HYDRAULIC SYSTEM					
Main Hydraulic Pump Type	Open/Crossed Centre	Closed Centre Load Sensing (CCLS)			
Hydraulic flow: main + steering/trans (l/min)	64 / 113 + 47	113 + 47			
Remote valves ²	3 rear		Classic: 2 rear, Ultimate: 3 rear		
Linkage Control type	Mechanical Hitch Control		Electronic Hitch Control (with fender control)		
Max. lift capacity at hook ends (kg)	5,628		6,220		
STANDARD TYRES³					
Rear & Front	540/65R38 & 440/65R28	600/65R38 & 480/65R28	540/65R38 & 440/65R28	600/65R38 & 480/65R28	
DIMENSIONS					
A: Overall Length (mm)	4,292	4,532	4,292	4,532	
B: Overall Height, Classic / Ultimate (mm)	2,846	2,900	2,759 / 2,944	2,759 / 2,944	
C: Minimum width (mm)	1,873	1,913	1,873	1,913	
D: Wheelbase, std/ front suspension (mm)	2412	2,652 / -	2,412 / 2,421	2,652 / 2,661	
Typical Working weight (kg)	4,900	5,300	5,130	5,500	

¹ ECE R120 corresponds to ISO 14396

² Additional valves optional

³ Other Tyres available 4 Calculated values

● = Standard ○ = Optional

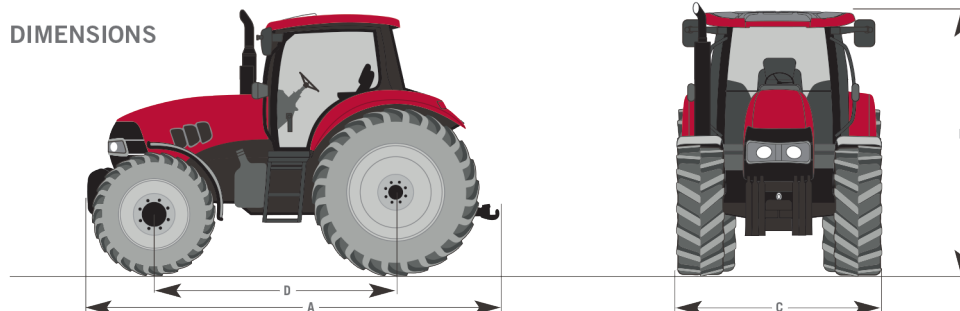

The data indicated in this folder are approximate. The models described here can be modified without the manufacturer's notice. The drawings and photos may refer to equipment that is either optional or intended for other countries. Please get in touch with our Dealer Network for any further information. Published by CNH Industrial. Printed for New Zealand - 11/22 - 10008/NZ

CASE IH



caseih.co.nz